

**INSTRUCTION MANUAL
for
WIND SPEED TRANSMITTER
MODEL A70-SL
DOCUMENT # 1298, Version E**

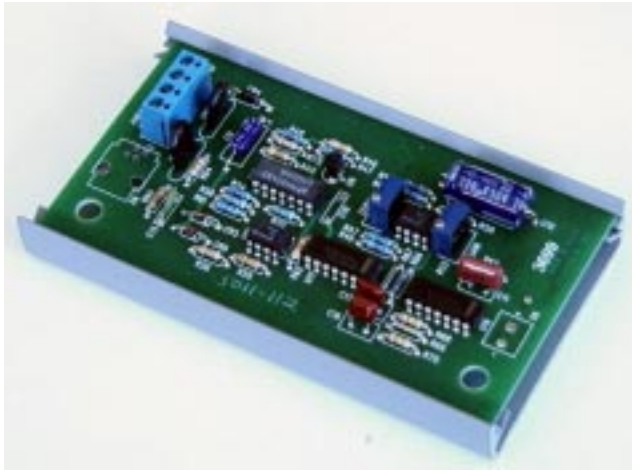

A70-SL-T Track Mount

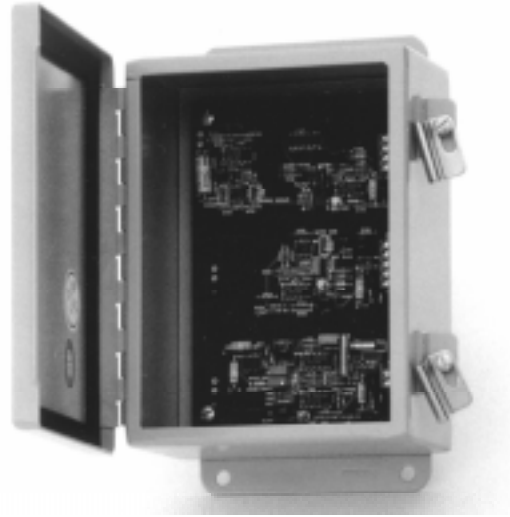

A70-SDPL-N12 in NEMA 12 Box

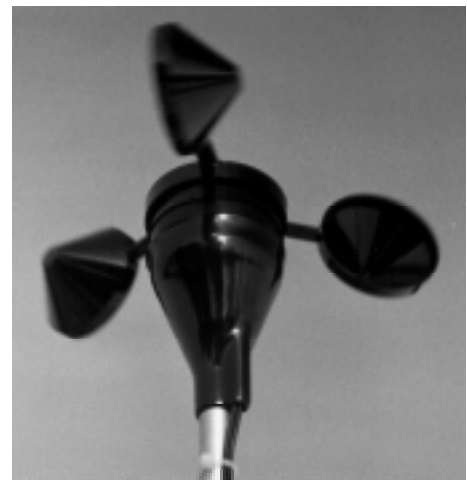

A75-104 Anemometer

Introduction

The A70 Wind Speed Transmitter converts the wind speed signal from the anemometer into an electrical signal for input to a computer, meters or other instrumentation. The output may be ordered to suit most requirements including 4-20 mA, 0-1 mA, 0-100 mV, 0-1 V, 0-5V for any range of wind speed input. Power may be supplied from 120Vac (A70-Sx6), 10-15Vdc (A70-Sx1), or 220 Vac (A70-Sx7).

Specifications

Operating Power	10 - 24 VDC
Input Device	A75-104 three cup anemometer Other sensors available
Range	/E - 0 - 100 MPH /M - 0 - 50 M/S /K - 0 - 160 KPH /K2 - 0 - 100 KPH
Accuracy	Electronics +/- 1% Anemometer see approp. data sheet
Temperature Range	0 to 60 degrees C standard -20 to 70 degrees C available
Dimensions	6.25"l X 4.05"w X 2"h
Weight	8 lb.
Maintenance	Recalibrate system yearly
Connectors	Terminal strip to accept AWG #12 to #22 wire
Mounting	Four 1/8" diameter holes
Special Requirements	External lightning arrestor recommended

Description

The A75-104 Anemometer is a rugged three cup device whose accuracy and reliability have been proven in wind tunnel and field tests over many years. The anemometer housing and rotor are fabricated of rugged Lexan. The rotor is supported by a beryllium copper shaft riding in Teflon bearings. The anemometer contains a small AC generator. The generator has a four pole magnet attached to the rotor shaft. As the magnet rotates it induces a voltage in a coil of wire mounted nearby. This voltage is transmitted to the electronics package via the sensor cable.

The Transmitter measures the frequency of the wind speed signal from the anemometer and converts it to a dc voltage. The voltage is then amplified and offset to provide the desired output signal.

The Transmitter may be in one of several packages. It may be track mounted for installation in an existing enclosure. It may be supplied in a steel NEMA 12 JIC box for inside deployment or in a steel NEMA 4 box when a weatherproof box is required.

DataChart Electronic Chart Recorder



Figure 1
Sensor Mounting

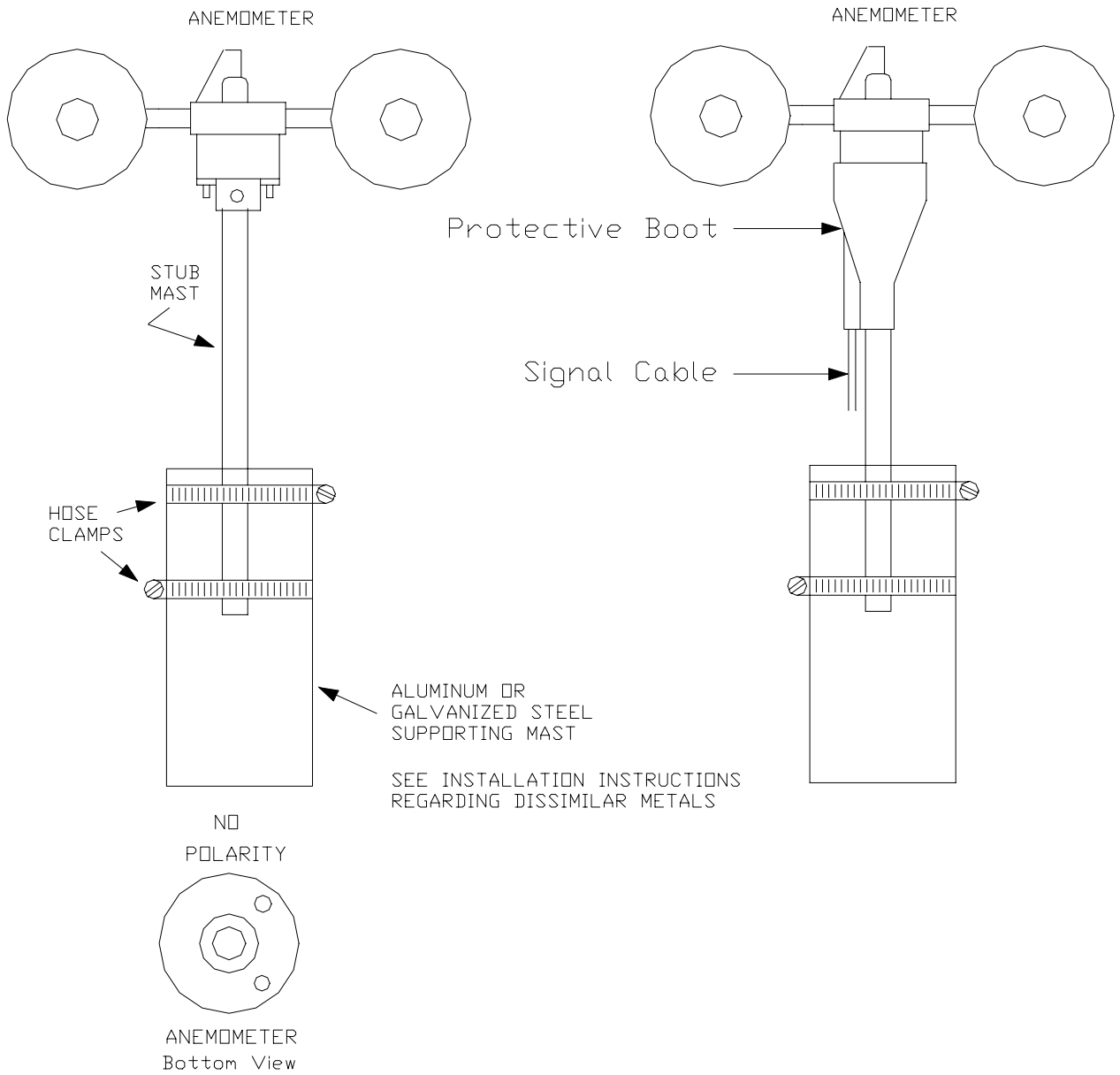

Installation

Select Location

Choose a suitable protected mounting location for the Transmitter near a source of appropriate operating power.

The anemometer head should be mounted at the point at which it is desired to sample the wind. Typically, it is located as high as feasible and well clear of obstructions.

Do not mount the anemometer directly above a vertical wall as this location often has accelerated and/or turbulent air flow.

It may be mounted on an existing structure, on a natural formation, or on a mast or tower. It is desirable to mount it so that the supporting structure will not influence the wind characteristics in its immediate vicinity; if it is mounted above a roof top or similar building structure, it should be high enough so that the wind deflected off the structure will not affect it, typically 5 to 10 feet or more.

If mounted to the side of a supporting structure it should be mounted at least ten structure diameters away to take the anemometer head out of the disturbed air around the structure; it should be mounted toward the prevailing wind; and it should be positioned so that the influence of structural members is minimized.

A preferred mounting that is commonly used is a telescopic tower for installations up to forty or fifty feet high; a tower commonly used for TV antenna support, consisting of concentric pieces of tubing approximately ten feet long, guyed at each section, is suitable. Above this height self-supporting or guyed lightweight structural towers can be used.

The A75-104 Anemometer must be attached to a rigid structure that doesn't sway or vibrate. Trees are not suitable for anemometer mounting. The rapidly rotating cups of the anemometer develop a centrifugal moment which resists the movement of the supporting structure. This quickly destroys the internal bearings and results in erratic output signals. The 05103 Wind Monitor is recommended for non-stationary applications

The anemometer head is designed to mount to a 1/2" diameter rod or tube; a 10" length of aluminum tubing is furnished with the sensor for convenience of mounting. If the mast is to be mounted on a metallic tower consideration must be given to galvanic corrosion that occurs between dissimilar metals. Attachment to galvanized steel towers using stainless steel hose clamps is acceptable. For other combinations of metals it is recommended to insulate electrically the stub mast from the tower with a plastic bushing or sheet. Alternatively, fabricate a stub mast from the same material as the tower. This consideration is especially important in locations exposed to salt spray and air.

Note the location of the 1/8" diameter holes in the anemometer base and in the top of the stub mast. Do not press on the anemometer rotor as the bearing may be damaged. Grasp the anemometer about its lower body and press it onto the stub mast. Align the 1/8" holes and secure the anemometer to the stub mast by passing the cotter pin through these holes. Attach the stub mast to the tower or other support using the two stainless steel hose clamps.

Slide the protective boot over the base of the anemometer after wiring is complete. Tape it to the mast to secure it in place.

Figure 2
Poor Wind Sensor Placement
Over Vertical Wall

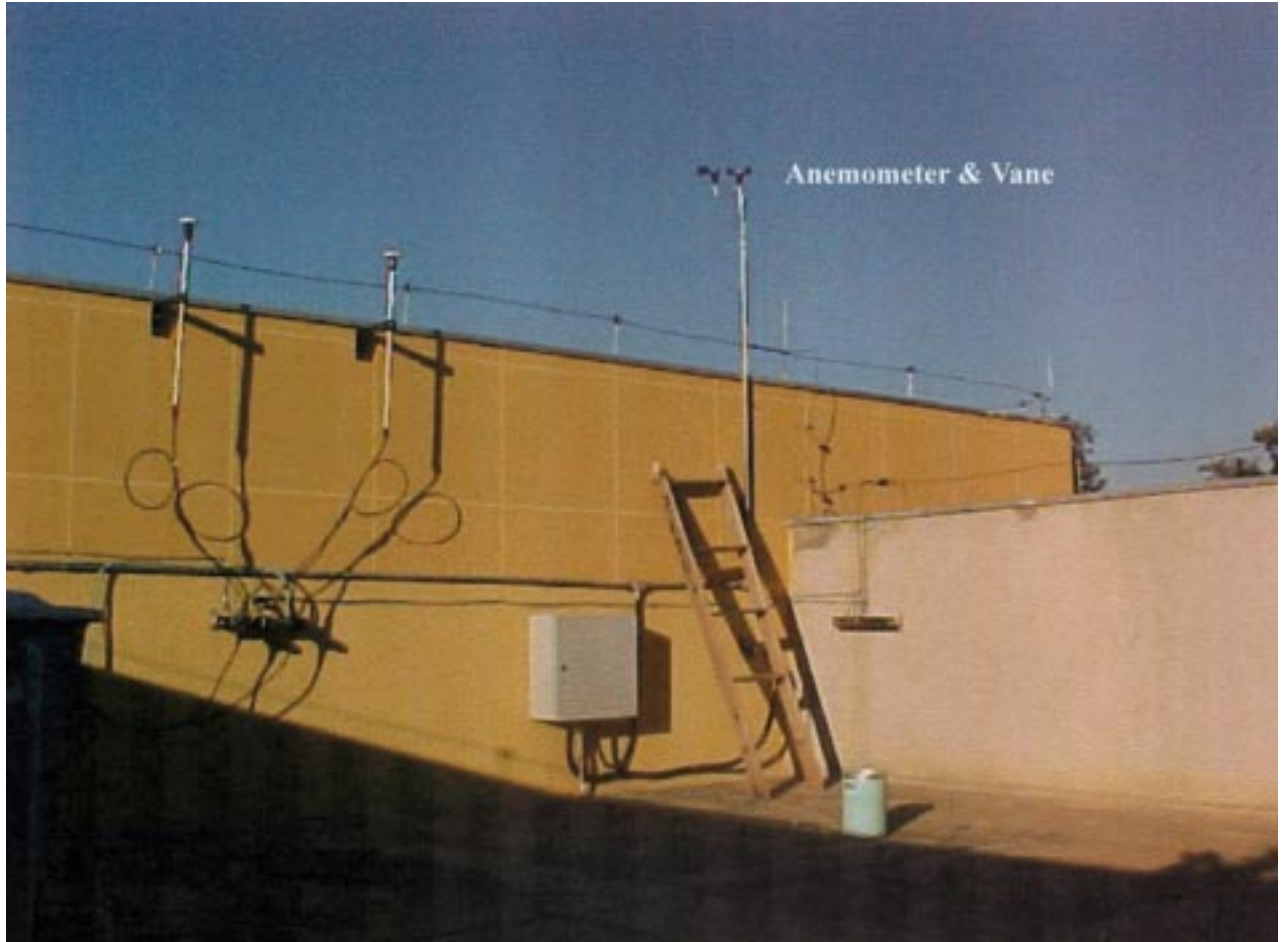

Installation (Cont.)

Wiring Considerations

The wire type is noncritical for most applications. If the wiring is located in an electrically noisy environment then the use of a twisted pair with shield is recommended. Connect the shield to ground at one end only. The insulation should be sunlight resistant. Polyethylene or polyvinyl chloride insulation is recommended.

Before proceeding verify that the maximum resistance of the current loop including the wiring and sensing element does not exceed the maximum given by Formula 1. If this resistance is exceeded the loop current will not attain full scale.

**Formula 1
Maximum Loop Resistance**

R - Maximum Loop Resistance in Ohms

V - DC Excitation Voltage

$$R = (V - 10 \text{ Vdc}) \times 50$$

The resistance of various gages of copper wire is given in Table 1.

It is recommended that the system be assembled and tested on the ground before final installation.

**A70-LPDA
Loop Powered Analog Display**



Wire Gage AWG	Resistance in Ohms per foot
12	.0016
14	.0026
16	.0041
18	.0065
20	.0103
22	.0165
24	.0262

Table 1

Wire Gage AWG	Resistance in Ohms per foot
12	.0016
14	.0026
16	.0041
18	.0065
20	.0103
22	.0165
24	.0262

**Figure 3
Graph of Maximum Loop Resistance**

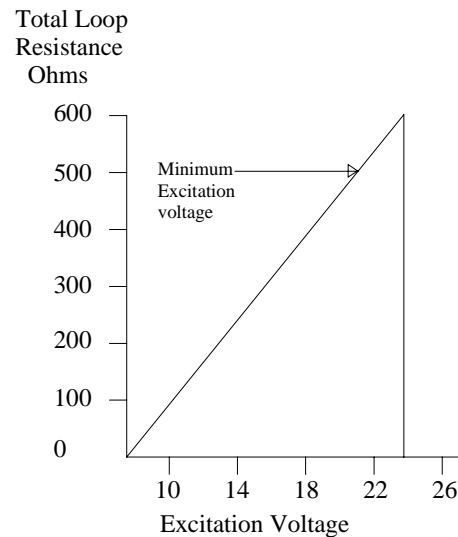

**A70-LPDD
Loop Powered Digital Display**



Installation (Cont.)

Connect the sensor cable to the anemometer using the end with the attached lugs. Polarity is not important. There are two brass studs with 4-40 thread that extend from the bottom of the anemometer housing. Attach the sensor cable to these studs being careful to tighten only the outer #4 hex nut. If the inner nut is loosened or the nuts are tightened simultaneously the stud may rotate. This may result in a poor electrical connection inside the anemometer.

Secure the sensor cable to the supporting structure at intervals of four feet or less. If the cable is allowed to vibrate in the wind a broken cable may result.

In locations exposed to corrosive atmospheres, such as salt air or smog, cover the wires and studs with a layer of electronic grade silicon rubber. Do Not use caulking grade silicon as it emits acetic acid as it cures that will corrode the connection.

It is recommended that the system be assembled and tested on the ground prior to final installation. Special consideration must be given to installations where the sensors or electronics will be exposed to strong radio frequency radiation or strong magnetic fields. Contact the factory for applications assistance

A70-SL POWER SUPPLY

Proper operation of the A70-SL Transmitter requires that the power supply provide a voltage in the range of 12-24 Vdc. Voltage ripple must be less than 100 volts per second for proper operation. The Transmitter is designed so that the loop current will not exceed approximately 30 mA under any circumstances.

Wiring Summary

1. See Figure 2. Locate the 2 wire, sixty foot anemometer cable and connect the spade lugs to the anemometer.
2. See Figure 3. Connect the anemometer signal cable to the input terminals 3 & 4 of the Transmitter.
3. See Figure 3. Connect the output signal to the load using terminals 1 & 2 of the Transmitter.

Note: The A70-SL is loop powered. The signal and power are supplied by the same wires.

Lightning Protection

The Transmitter electronics and A75-104 Anemometer have integral metal oxide varistors for protection from lightning induced surges, electrostatic discharge and other atmospheric discharges. Wind blown aerosols such as sand and snow can generate electrostatic charges with consequences similar to lightning discharges. The A96 Series of gas tube surge arrestors can safely dissipate much higher energy discharges than the internal varistors.

A consequence of the rapid rise time of these electrostatic discharges is the inductance of the grounding system and interconnecting wiring is generally of more concern than resistance. Gas tube surge arrestors should be placed as close to the device they are intended to protect to minimize the inductance in the wiring.

In highly exposed systems the sensors should be protected by gas tube surge arrestors located as closely as possible to them, typically 12 inches or less. The Transmitter electronics can benefit from another set of gas tube surge arrestors located where the sensor wiring enters the control building. Gas tube surge arrestors are indicated in any system with underground wiring.

Figure 4
A70-SL Component Layout

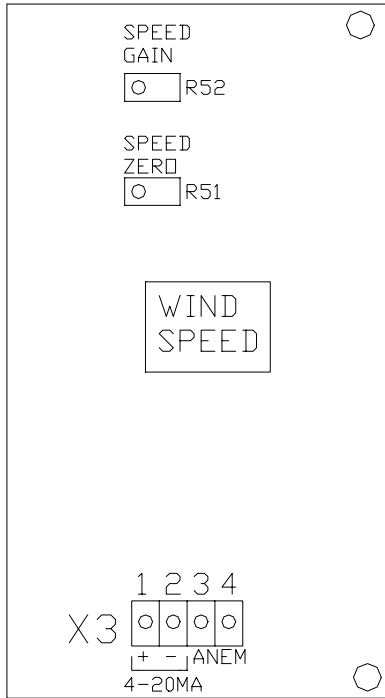

NO
POLARITY

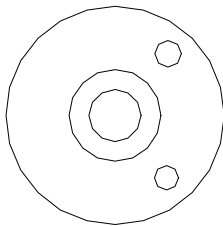

ANEMOMETER

BOTTOM VIEW

Figure 5
Connection Diagram

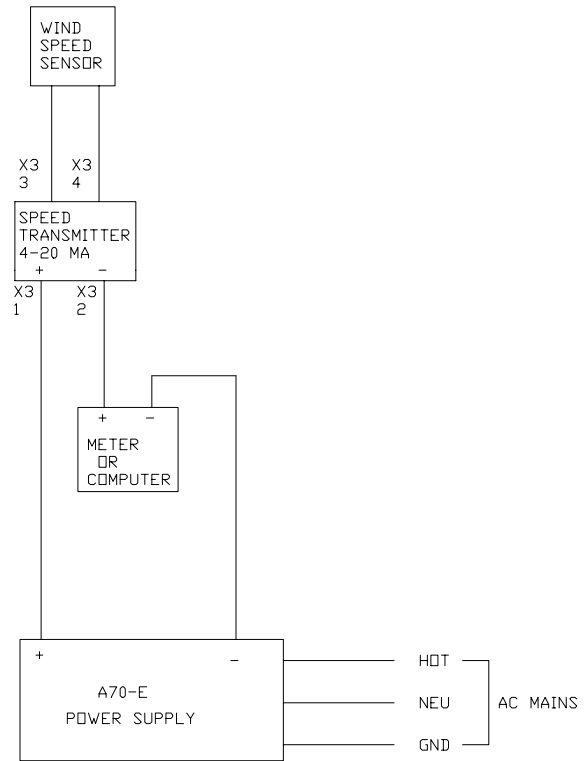

A96-100P Surge Arrestor

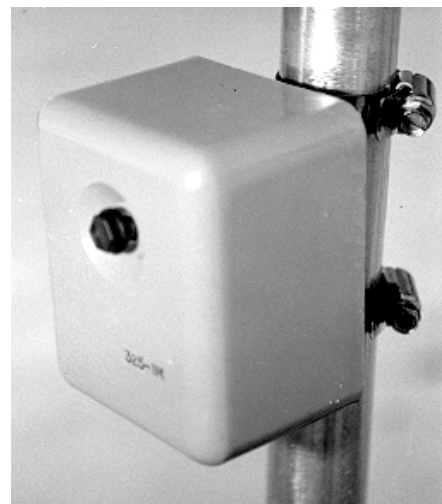
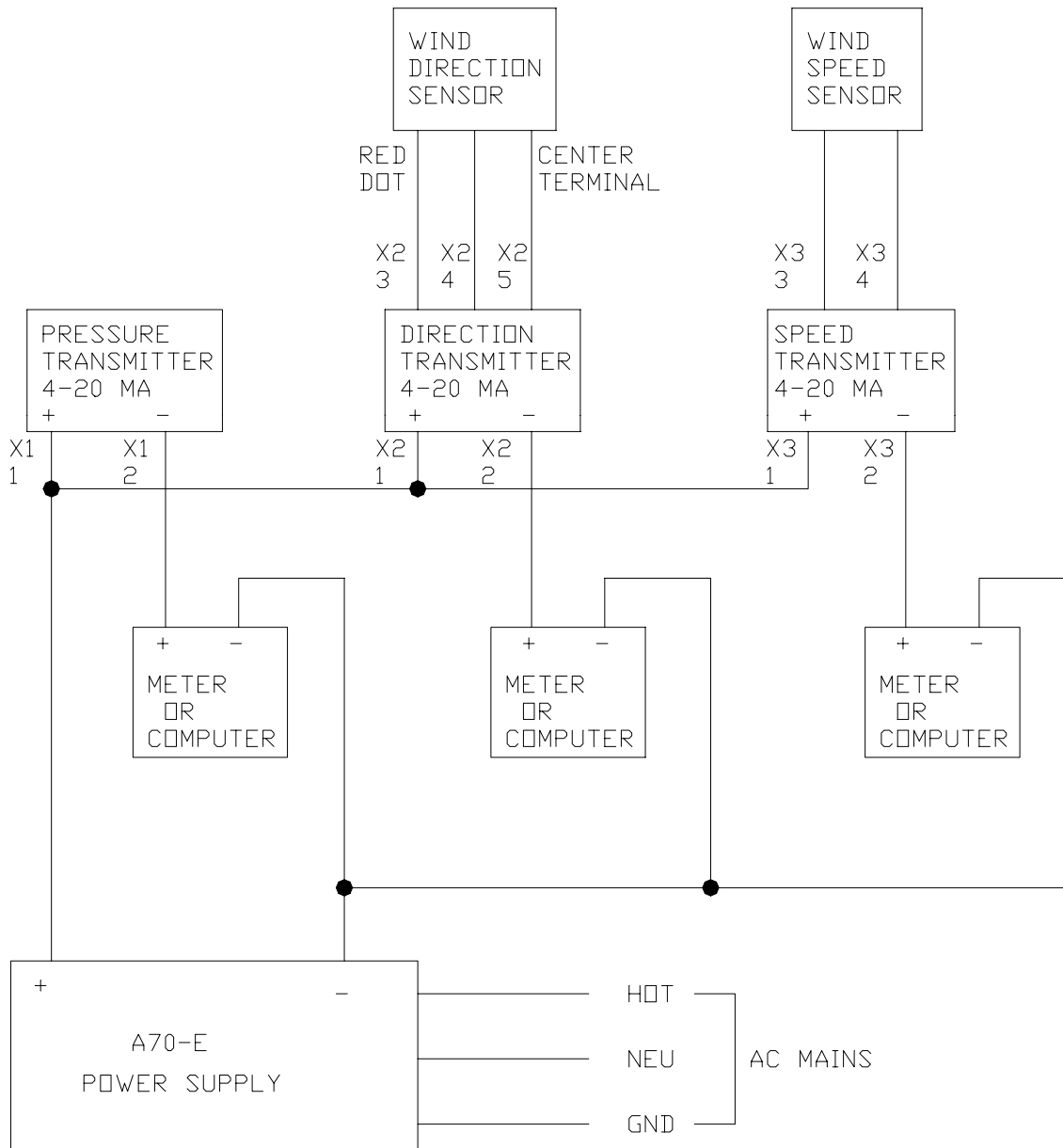

Figure 6
Multiple Transmitters with One Power Supply



OPERATION

Operation of the system is fully automatic and commences when electrical power is supplied.

Note: Wind speeds greater than 110% of the specified maximum may produce outputs indicating less than full scale

For Model **A70-SL/E** the wind speed may be determined from the output current with the use of Formula #2.

S - Wind Speed in Miles Per Hour
I - Loop current in mA

S = (I - 4) X 100/16 Formula 2

For Model **A70-SL/M** the wind speed may be determined from the output current with the use of Formula #3.

S - Wind Speed in Meters per Second
I - Loop current in mA

S = (I - 4) X 50/16 Formula 3

Figure 7
Graph of Wind Speed Transfer Function

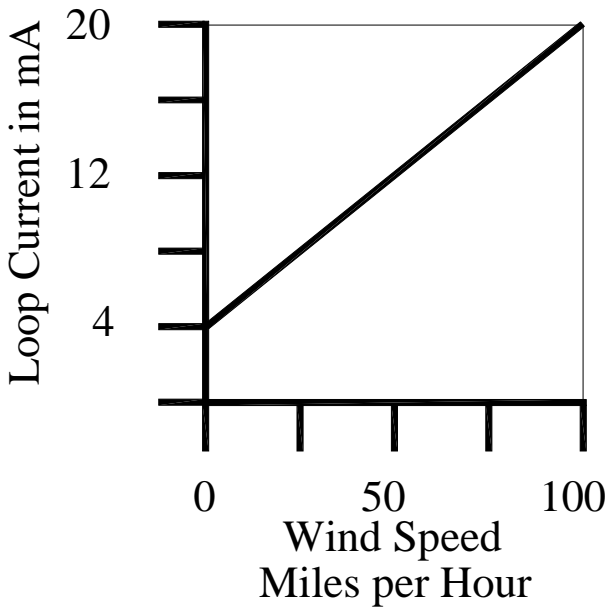
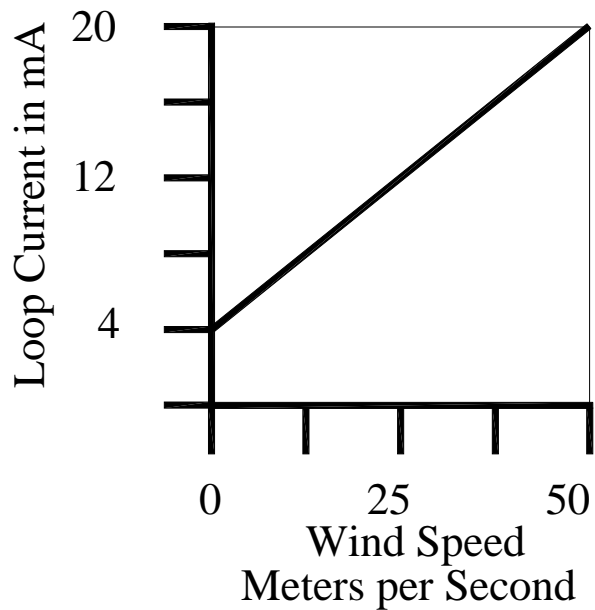

Figure 8
Graph of Wind Speed Transfer Function



For Model **A70-SL/K** the wind speed may be determined from the output current with the use of Formula #4.

S - Wind Speed in Kilometers Per Hour
 I - Loop current in mA

$$S = (I - 4) \times 160/16 \quad \text{Formula 4}$$

Figure 9
Graph of Wind Speed Transfer Function

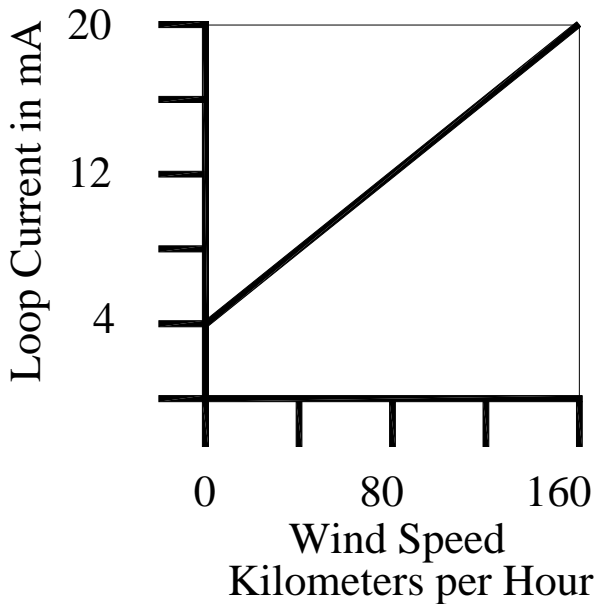

It is possible to monitor the loop current indirectly by measuring the voltage drop across a known resistance installed in series with the current loop.

Voltage Across Sensing Resistor

I - Loop Current in Milliampers
 R - Resistance in Ohms
 $V = I \times R / 1000$ **Formula 5**
 V - Voltage in Volts

Figure 10
Graph of Voltage Vs Loop Current for 100 ohm Load

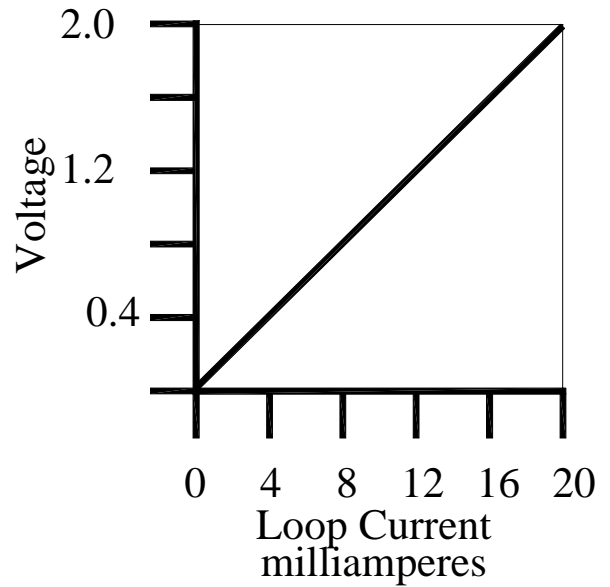

ICING

Under some conditions operation of the anemometer will be degraded by the presence of ice. This most often occurs as the result of freezing rain. The condition quickly clears when sunshine heats the anemometer causing the ice to melt. The condition may persist for hours or days in the absence of bright sunshine. No permanent damage is done to the anemometer. The HAE Heated Anemometer is recommended in applications where it is necessary to prevent ice build up.

HAE Heated Anemometer



MAINTENANCE

SENSORS

It is recommended that the sensors be checked for calibration each year. This can be accomplished by comparison with a portable anemometer or by wind tunnel testing.

TRANSMITTER

It is recommended that the Transmitter be checked for calibration each year. Refer to Calibration section for details.

Model C47 Wind Alarm



CALIBRATION

The instrument is fully calibrated at the factory before shipment. The following procedure is provided should adjustment be necessary in the future.

WIND SPEED

The wind speed section consists of a frequency to current converter. A function generator frequency counter and milliammeter are required for calibration.

Note: Calibration potentiometer may be sealed with silicon rubber to prevent tampering by unauthorized personnel.

Model A70-SL

1. Refer to Figure 2. With loop power supplied and no speed signal, adjust the potentiometer marked "SPEED ZERO" to produce a loop current of 4 mA.
2. Inspect Table 2 and apply a suitable sinusoidal signal with a RMS amplitude between 3.5 and 5 V to simulate the output of the A75-104 Anemometer. Consult the factory for calibration of other anemometers.
3. Adjust the potentiometer marked "SPEED GAIN" to produce a loop current of 20 mA.

Table 2

Anemometer Output Frequency

100 MPH	58.54 Hz
160 KPH	58.06 Hz
50 M/Sec	65.48 Hz

A76-T10 Tripod Tower



TROUBLE SHOOTING PHILOSOPHY

Effective trouble shooting requires that problem locations be systematically eliminated until the problem is found.

There are four basic questions to answer when trouble shooting (Ref. #1):

1. Did it ever work right?
2. What are the symptoms that tell you it's not working right?
3. When did it start working badly or stop working?
4. What other symptoms showed up just before, just after, or at the same time as the failure?

It is best to write down any clues you may obtain. Be sure to write down anything unusual.

The response to question #3 should probably not be 3:04 P.M. A useful response might be, "Just after an electrical storm." or, "Just after it fell off the shelf."

Double check all the simple solutions to the problem before searching for complex ones. If the problem occurs right after installation, it probably has a simple solution.

If an automobile engine cranks, but doesn't start, make sure there is fuel in the tank before replacing the engine. If the electronic equipment doesn't function verify that it has power and is turned on.

Systems containing parts which can be quickly interchanged are easy to trouble shoot. Swap parts until the problem moves. The location has then been narrowed to the part that caused the problem to move.

Sometimes there are multiple problems. These reveal themselves in layers much like peeling an onion.

It often helps to explain the problem to another person, even if that person is not knowledgeable about the particular piece of equipment.

This does two things. First it requires you to organize the situation so it can be explained to another. Secondly, it may turn out that you are so familiar with the situation that you have overlooked the obvious. Another person unfamiliar with the equipment may be able to help.

If you are unable to solve the problem, put it aside until the next day. Some new thoughts will probably occur while working on another project.

References

1. "Troubleshooting is More Effective with the Right Philosophy", Robert A. Pease, Electronic Design News, January 5, 1989.

TROUBLE SHOOTING

Wind Speed

Loop Current: 0 mA

Failure Description

- Current loop polarity reversed
- Open circuit in cable
- Power supply failure
- Transmitter failure

Loop Current : Less than 4 ma

Failure Description :

- Low power supply voltage
- Loop resistance too high

Loop Current : Constant 4 ma

Failure Description :

- Anemometer cable shorted
- Anemometer coil open

Loop Current : Constant 20 - 22 ma

Failure Description :

- Power line interference
- Open anemometer cable

Loop Current : Greater than 25 ma

Failure Description :

- Transmitter failure

Loop Current : Does not reach 20 ma, otherwise operates properly

Failure Description :

- Low power supply voltage
- Loop resistance too high

ANEMOMETER TESTING:

The anemometer at rest should exhibit a resistance of 400-600 ohms. This can be tested from the Transmitter end of the signal cable. Disconnect cable from Transmitter and use ohm meter. A fluctuating resistance will result if the anemometer turns during the test.

A resistance greater than 1000 ohms indicates an open circuit (break in cable). If this occurs after a period of normal operation the cable may have broken in a section where it was allowed to vibrate in the wind.

A resistance less than 100 ohms indicates a short circuit. Any splices in the sensor cable should be suspect if an open or short circuit occurs.

If an ohm meter is unavailable connect anemometer to translator with a short length of cable. If problem is remedied, trouble is in the cable.

ANEMOMETER SIMULATION:

The A75-104 Anemometer produces an AC signal whose frequency and amplitude are proportional to wind speed. The instrument measures the frequency and is relatively insensitive to the signal's amplitude.

The frequency is 0 Hz at 0 mph and 60 Hz at 102.5 mph (45.8 M/Sec.) See Table 2 for other units of wind speed. The amplitude varies from 0 V RMS at 0 mph to 3.67 V RMS at 102.5 mph.

This signal may be simulated with a function generator or a transformer connected to the electric utility. A transformer with a 6 V output is sold at most hardware stores for use in home door bell circuits.

LIMITED WARRANTY

COMPTUS INC. extends this warranty to the original consumer only. Any product manufactured by Comptus is warranted against defect for a period of ONE YEAR beginning on the date of purchase by the consumer or two years beginning on the date of purchase from Comptus by the authorized dealer, whichever expires sooner.

TO OBTAIN WARRANTY SERVICE, the purchaser must contact Comptus and receive return authorization. Such correspondence should be addressed to: Comptus INC., 342 Lyndeboro Rd., New Boston, N.H. 03070. All warranty service is performed at the factory. All incidental expenses, including shipment of products to Comptus by the purchaser, shall be the sole responsibility of the purchaser.

WARRANTY SERVICE is at the sole discretion of Comptus and free of charge for parts and labor. Under the above terms, Comptus will repair or replace the defective component(s), provided that:

- a) the product has not been subjected to abuse, neglect, accident, alteration, improper installation or servicing, or used in violation of instructions furnished by Comptus;
- b) the product has not been repaired or altered by anyone except Comptus or its authorized service agencies;
- c) the serial number has not been defaced, removed, or otherwise changed;
- d) the damage has not been caused by acts of nature including windstorm and hail beyond those specified as within the range of operating conditions;
- e) the damage has not been caused by shipping.

THIS WARRANTY IS IN PLACE OF ALL OBLIGATIONS OR LIABILITIES ON THE PART OF COMPTUS FOR DAMAGES. IT DOES NOT APPLY TO ANY COMPONENT OR EQUIPMENT RESOLD BY COMPTUS IN ITS ORIGINAL CONDITION AS RECEIVED BY COMPTUS FROM THE MANUFACTURER OR DISTRIBUTOR, AMONG THE DAMAGES EXCLUDED FROM THIS WARRANTY ARE ANY INCIDENTAL OR CONSEQUENTIAL DAMAGES ARISING OUT OF OR IN CONNECTION WITH THE PRODUCT IN ANY WAY.

Any implied warranties are limited in duration to the duration of the written warranty. No representative or person is authorized to give any other warranty or assume for Comptus any other liability in connection with the sale of its products.

THIS WARRANTY GIVES YOU SPECIFIC LEGAL RIGHTS, AND YOU MAY ALSO HAVE OTHER RIGHTS WHICH VARY FROM STATE TO STATE. SOME STATES DO NOT ALLOW THE EXCLUSION OR LIMITATION OF INCIDENTAL OR CONSEQUENTIAL DAMAGES OR LIMITATIONS ON HOW LONG AN IMPLIED WARRANTY LASTS, SO THE ABOVE LIMITATIONS AND/OR EXCLUSIONS MAY NOT APPLY TO YOU.

This warranty complies with the Magnuson-Moss Consumer Warranty Act, and completely replaces any warranty printed on promotional material describing products of Comptus Inc.

ISO 9001 Registered

Comptus Inc[®] 342 Lyndeboro Rd., New Boston, NH USA
Phone: 603 487-5512 Fax: 603 487-5513 E-mail: sales@comptus.com

HOW TO RETURN EQUIPMENT TO COMPTUS

1. Contact the Comptus Service Department with the model and serial number of the unit. Be prepared to provide the symptoms of the problem as many are solved without the need for returning the equipment. Have a person with firsthand experience of the trouble on hand to provide specific information.

2. Comptus will issue a Return Material Authorization Number (RMA #) if required. This will ensure the fastest response and least cost for all parties. Please reference this number in all correspondence. This number should be printed on the shipping container.

3. Include a description of the service desired with the returned equipment. If the equipment is being returned for repair, please include a description of the problem.

4. If the equipment is packaged in a plastic case, wrap it in aluminum foil or other conductive material. This will protect it from static electricity, as well as prevent the packing material from jamming mechanical parts, such as switches.

Otherwise, place the equipment in a plastic bag, again to prevent contamination by packing material.

Place the equipment in a suitable shipping container and fill with packing material. There should be at least one inch of packing material between the equipment and the shipping container on all sides.

5. Equipment will be returned C.O.D. to sender if any charges are incurred, unless other arrangements are made in advance.

SHIP THE EQUIPMENT TO:

Comptus Inc.
342 Lyndeboro Rd.
New Boston NH 03070 U.S.A.

Telephone 603 487-5512
Telfax 603 487-5513
Email : service@comptus.com

NOTE: Please be sure to include the RMA Number, as described in Item 1, on the shipping container.

ISO 9001 Registered

Comptus Inc[®] 342 Lyndeboro Rd., New Boston, NH USA
Phone: 603 487-5512 Fax: 603 487-5513 E-mail: sales@comptus.com

ISO 9001 Registered

Comptus Inc[®] 342 Lyndeboro Rd., New Boston, NH USA
Phone: 603 487-5512 Fax: 603 487-5513 E-mail: sales@comptus.com

Model A70-SL
Component Packing List

Quantity received	Description	Quantity Re- ceived
1	A70-S Transmitter	_____
1	Anemometer	_____
1	Anemometer Boot	_____
1	Stub Mast	_____
1	60 ft. Cable	_____
1	Instruction Manual	_____
2	Hose Clamps	_____
1	Certificate of Calibration	_____

IMPORTANT: Please check your order on receipt to be certain all listed accessories are included before discarding shipping container or packing material. All shortages must be reported within 10 days of receipt.

ISO 9001 Registered

Comptus Inc[®] 342 Lyndeboro Rd., New Boston, NH USA
Phone: 603 487-5512 Fax: 603 487-5513 E-mail: sales@comptus.com